

Operating Instructions



J102 - Junior Pro

Table of contents

03	Introduction
03	About these instructions
03	Safety information
04	Contents
05	Overview
07	Starting Up
09	Operation
13	Precautions
15	Technical data
16	Troubleshooting
18	Shutting down
19	Maintenance
19	Transport and Storage
19	Disposal

Introduction

Promoting hydrogen technology during training by way of experiments: Our JUNIOR series offers a cost-effective and multifaceted range of possibilities for this purpose. Excellent functionality, easy experiment setups and speedy results allow for quick learning outcomes.

With the JUNIOR Pro, all hydrogen technology components, such as the solar cell, electrolyzer, hydrogen/oxygen storage tank, fuel cell and electrical load, are mounted to a base plate and ready for experimentation. The JUNIOR Pro allows users to carry out a number of stimulating experiments themselves in just a few simple steps.

We hope you conduct many exciting experiments and gain interesting insights into hydrogen technology.

H-TEC EDUCATION

About these instructions

- These operating instructions are intended for the supervisor in charge.
- These operating instructions should be read and observed before use.
- These operating instructions should be available for reference and be stored in a safe place.
- All safety instructions should be observed.
- This product may only be put into operation and operated under the directions of the responsible supervisor.

Safety information

Read and observe the [General Safety Instructions](https://h-tec-education.com/manuals/safety-instructions.pdf) found on our website before using the product. <https://h-tec-education.com/manuals/safety-instructions.pdf>

Product-specific safety information

The product should only be used:

- according to the intended use
- in compliance with all safety information

The components of this product feature freely accessible, live electric contact surfaces. Connecting to an impermissible operating voltage may result in a fire hazard, a risk of electric shock and damage to the components.

The product may only be operated under the constant supervision of an adult trained in the handling of this product.

The product can be operated in a display cabinet or similar, provided adequate ventilation is ensured. The water bottle included with the product is to be filled only with distilled water ($\sigma < 2 \mu\text{S}/\text{cm}$).



1x Instructional model JUNIOR Pro



1x water bottle



1x carrying case with insert



1x companion textbook



1x operating instructions

Overview

The JUNIOR Pro instructional model at a glance

The JUNIOR Pro instructional model consists of a solar module, an electrolyzer, two gas storage tanks for hydrogen and oxygen, a fuel cell and an electrical load, all mounted to a base plate. When the solar module receives an adequate amount of light, the electrolyzer produces hydrogen and oxygen using distilled water. The gases are stored temporarily and then enter the fuel cell, where they are converted back to water while electrical energy and heat are being generated. The individual components are shown in the following graphic.

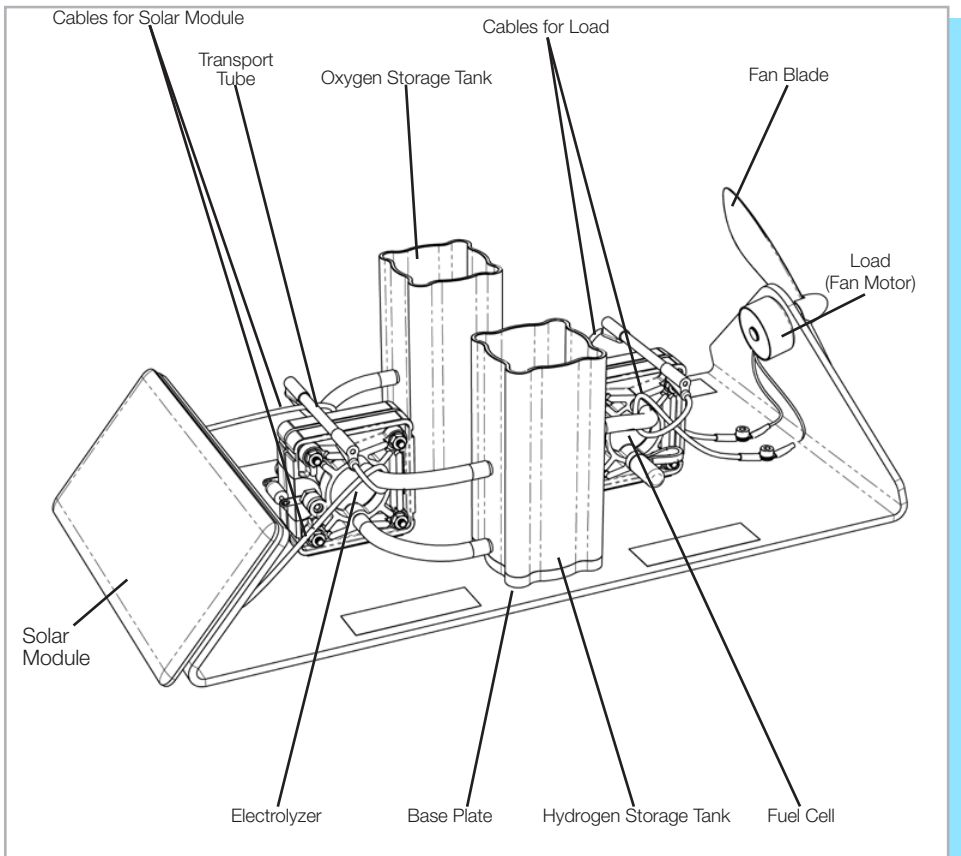

Fig. 1: The instructional model at a glance (Note: Junior Pro will have taller Storage Tanks than those depicted)

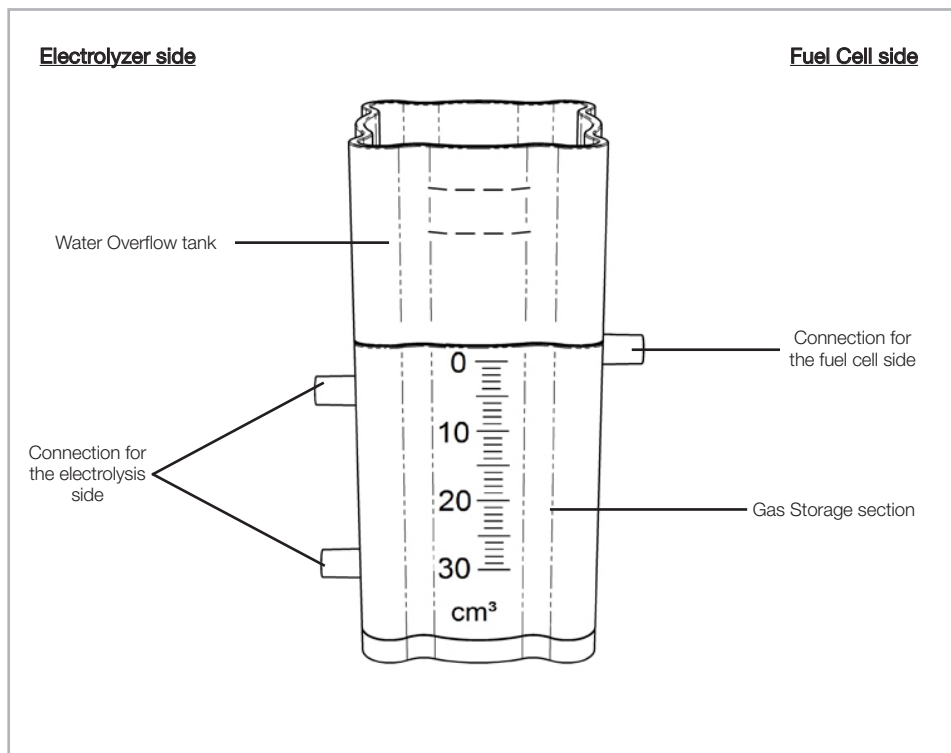

Fig. 1: The gas storage tank at a glance

To use the product, disconnect the connection to the fuel cell and fill with distilled water ($\sigma < 2 \mu\text{S}/\text{cm}$); see Chapter "Starting up". Do not fill past MAX level. Then, reconnect the fuel cell to the storage tanks.

Draining the gas storage tanks is described in Chapter "Shutting down".

Starting up

Assembly

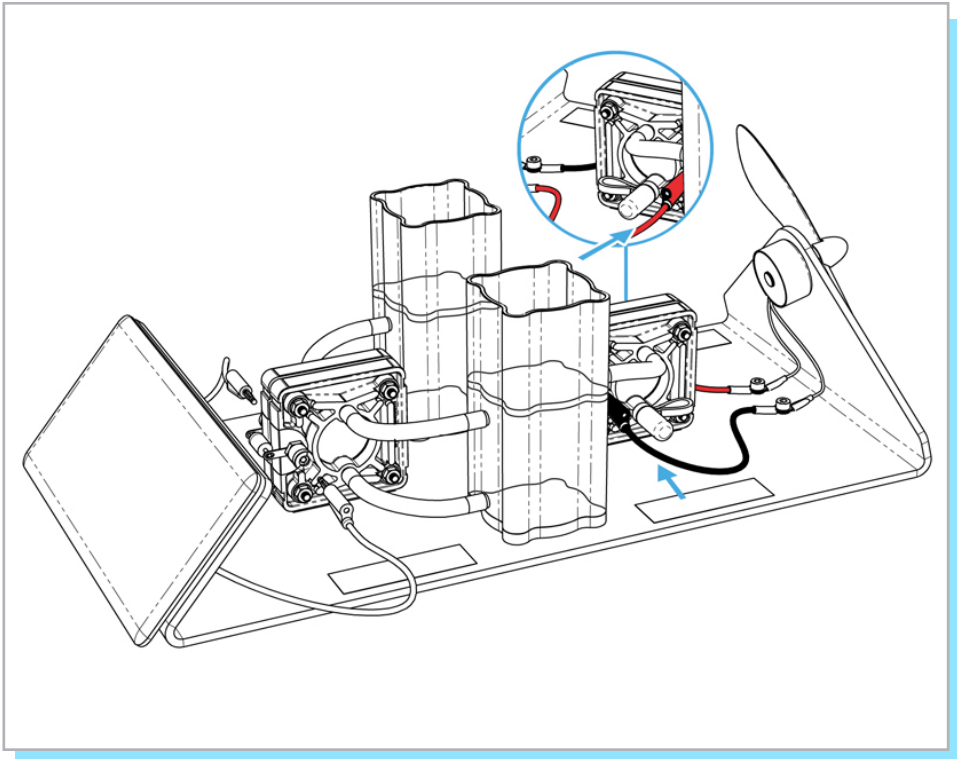

Fig. 3: Assembly

Assemble the instructional model as shown in Figure 3.

- Connect the tubes to either side of the storage tanks, ensuring the top port of the fuel cell is connected with the clamp in the closed position, and the bottom port is capped.
- Connect the cables of the load with the respective connection of the fuel cell while ensuring correct polarity (red = "+", black = "-").

Do not connect the solar panel to the electrolyzer yet.

The preparation for storage and transportation is carried out in reverse order to assembly.

Filling

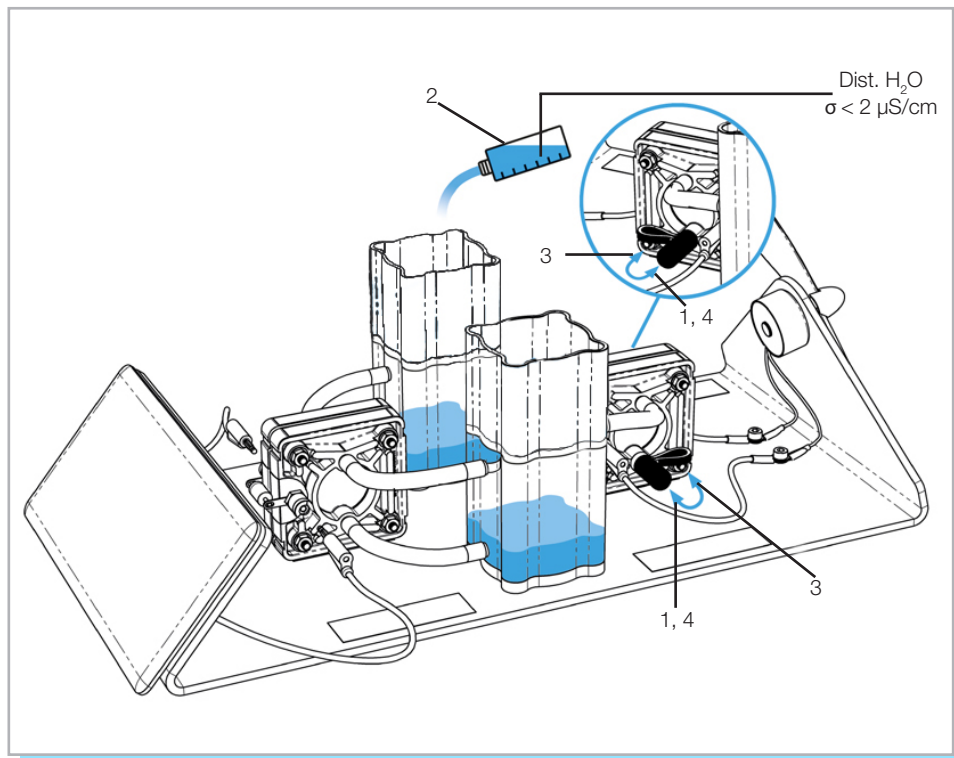

Fig. 4: Filling

- 1. Close both caps on the fuel cell.
- 2. Fill both gas storage tanks up to the lower fill level marking with distilled water ($\sigma < 2 \mu\text{S/cm}$) as shown in Figure 4.
- 3. Open both caps on the fuel cell. The water passes from the compensation tank to the storage section.
- 4. Once all the water has passed from the compensation tank to the storage section, close both caps on the fuel cell again.

Do not connect the power source to the electrolyzer yet.

Operation

The JUNIOR Pro instructional model can be used in two different operating modes. In “Storage Mode”, hydrogen and oxygen are stored temporarily in the gas storage tanks. In this operating mode, the instructional model can be used to carry out experiments. In “Demonstration Mode”, no gas storage takes place. This operating mode is reserved for demonstration purposes only. The “Storage” and “Demonstration” modes are described separately in the two sections below.

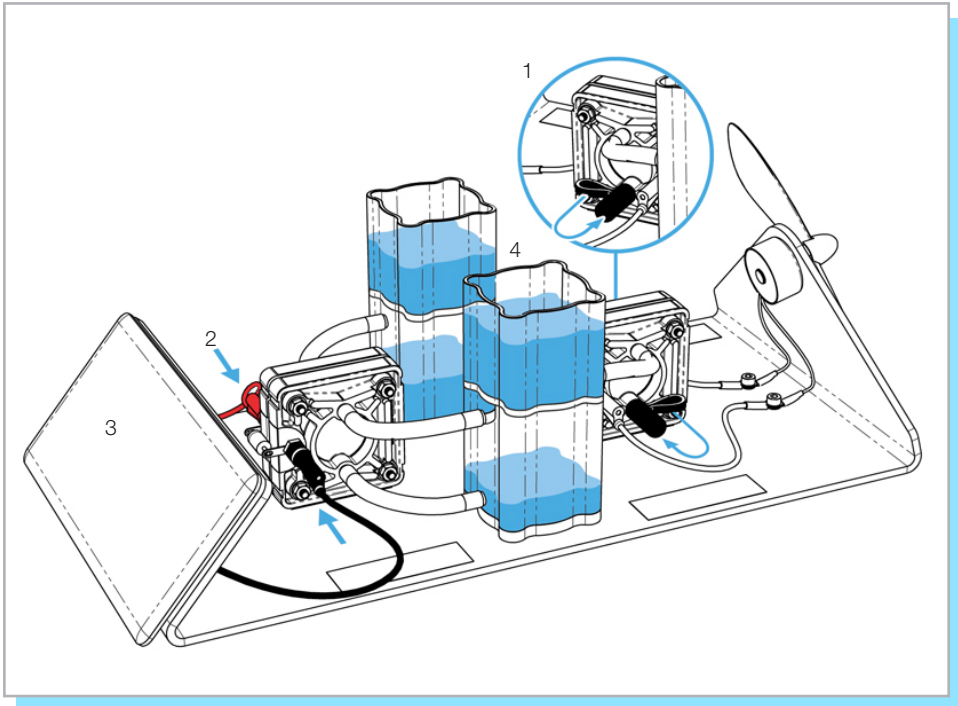

Fig. 5: Operating the JUNIOR Basic in Storage Mode

- 1. Close both caps on the bottom ports of the fuel cell.
- 2. Connect the cables of the solar module with the respective connection of the electrolyzer while ensuring correct polarity (red = “+”, black = “-”). If using an alternative power source, make sure to comply with the electrical specifications as defined in the technical data.

- 3. Provide the solar module with adequate direct sunlight or with light from a powerful, concentrated electrical light source. The water is split into hydrogen and oxygen at a ratio of 2:1.
- 4. If the storage section of the hydrogen storage tank is filled with gas, excess gas escapes as bubbles. Gas production must be stopped. For this purpose, remove the connecting cables on the power source from the respective connections on the electrolyzer.

Carry out the following steps to purge the remaining air from the tubes and the fuel cell:

- Open the caps on both sides of the fuel cell, one after the other, and let the stored gases completely flow through the fuel cell.
- Next, close the respective cap again. The propeller will start to rotate.
- Reconnect the previously used power source to the electrolyzer. The water is split into hydrogen and oxygen at a ratio of 2:1. If the storage section of the hydrogen storage tank is filled with gas, excess gas escapes as bubbles. Gas production must then be stopped by disconnecting the power source from the electrolyzer. The JUNIOR Basic is now in storage mode.
- After disconnecting the power source from the electrolyzer, continue operating the fuel cell until the propeller stops by itself. The water will then have fully returned to the storage section of the respective gas storage tank.

During operation, small amounts of water pass through the electrolyzer's polymer electrolyte membrane (PEM) from the oxygen side to the hydrogen side. This may cause the water level to rise on the hydrogen side and fall on the oxygen side. In addition, water is being consumed during operation.

Before hydrogen and oxygen are to be stored again, the water levels in the gas storage tanks need to be checked and, if necessary, adjusted.

The water levels in the gas storage tanks should be between the Min and the Max mark. If this is not the case, the water levels should be adjusted as follows:

- Connect the electrolyzer to the power source and continue operation until the compensation tanks are completely filled with water, and excess gas from both tanks escapes as bubbles. (Note: a small amount of splashing or overflow may occur)
- If the water level needs to be adjusted, gas production must be stopped. For this purpose, remove the connecting cables on the power source from the respective connections on the electrolyser. Using the water bottle, suck out or add water, as appropriate, until the water levels in both compensation tanks are again at the level of the lower fill level marking.
- Once the water level has been adjusted, you can continue in storage mode. To this end, carry out the process steps described in "Operation/storage mode" again.

Demonstration mode

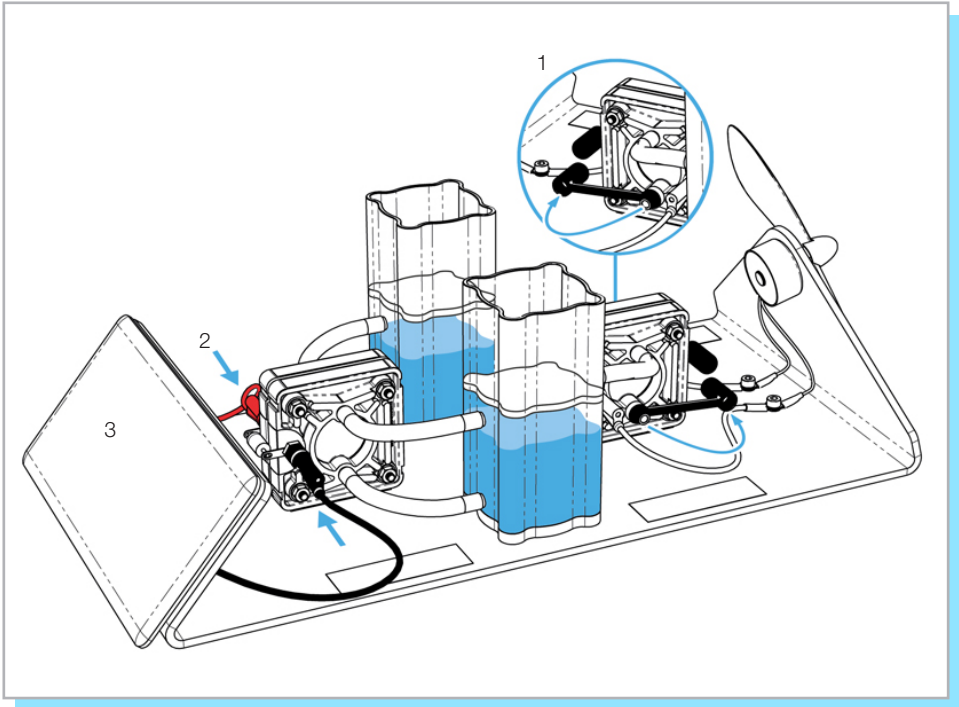

Fig. 6: Operating the JUNIOR Pro in Demonstration Mode

1. Open both caps on the fuel cell.
2. Connect the cables of the solar module with the respective connection of the electrolyzer while ensuring correct polarity (red = "+", black = "-"). If using an alternative power source, make sure to comply with the electrical specifications as defined in the technical data.
3. Provide the solar module with adequate direct sunlight or with light from a powerful, concentrated electrical light source. The water is split into hydrogen and oxygen at a ratio of 2:1.
4. The JUNIOR Pro is now in operation. The propeller will start to rotate as soon as the hydrogen and the oxygen reach the fuel cell. Warm-up takes approximately 4 minutes. If lighting conditions are extremely poor, warm-up may take longer.

During operation, small amounts of water pass through the electrolyser's polymer electrolyte membrane (PEM) from the oxygen side to the hydrogen side. This may cause the water level to rise on the hydrogen side and fall on the oxygen side. In addition, distilled water is being consumed during operation. For this reason, check the water level during operation.

The water levels in the gas storage tanks should be between the 5 mL and the 15 mL mark. If this is not the case, the water levels should be adjusted as follows:

- Close both caps on the fuel cell. Continue operation until the compensation tanks are completely filled with water, and excess gas from both tanks escapes as bubbles. (Note: a small amount of splashing or overflow may occur)
- If the water level needs to be adjusted, gas production must be stopped. For this purpose, remove the connecting cables on the power source from the respective connections on the electrolyzer.
- Adjust the water levels in the compensation tanks. Using the water bottle, suck out or add water, as appropriate, until the water levels in both compensation tanks are again at the level of the lower fill level marking.
- Open both caps on the fuel cell again.
- Once the water level has been adjusted, you can continue in demonstration mode. To this end, carry out the process steps described in “**Operation/ Demonstration Mode**” again.

Precautions

 CAUTION

Risk of injury from hot surfaces!

The surface of solar modules may become very hot during operation. Touching the surface of solar modules may cause injuries. Do not touch the surface of solar modules during operation. Do not touch the surface of solar modules even after operation until they have cooled down to below 60°C.

 CAUTION

Risk of injury from hydrogen ignition!

Escaping hydrogen may ignite when in proximity to an ignition source. Prevent hydrogen from being released into the atmosphere. Stop hydrogen production as soon as the hydrogen storage tank is filled with hydrogen.

 CAUTION

Risk of injury from hot surfaces!

The protection diode on the electrolyzer becomes very hot in case of incorrect polarity. Touching the protection diode may cause injuries. Before starting up, ensure correct polarity of the connecting cables and the electrical connections (red = "+", black = "-"). Do not touch the protection diode.

 CAUTION

Risk of injury from hydrogen ignition!

Damaged tubes or leaking connections may cause hydrogen to escape. Hydrogen and hydrogen-air mixtures may ignite when in proximity to an ignition source. Check tubes and connections for damage before each setup and before each use.

 CAUTION

Risk of fire due to electrical overload!

Any operation beyond the electrical specifications will lead to excessive overheating of the electrolyser. This may cause a fire. Never operate the electrolyzer beyond the electrical specifications stated in the technical data.

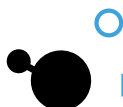

CAUTION

Risk of damage through insufficient distance to lamps.

The solar module may become excessively hot or sustain irreparable damage if it is too close to the lamp. Observe the minimum distance defined by the manufacturer when operating solar modules with lamps.

CAUTION

Risk of damage due to voltage.

Applying voltage to a fuel cell or a solar module leads to irreparable damage to the components. Do not apply voltage to fuel cells and solar modules.

CAUTION

Risk of damage due to improper handling.

Operating the electrolyzer using water with an electrical conductivity of $\sigma < 2 \mu\text{S}/\text{cm}$ will cause irreparable damage to the electrolyser. Only fill the electrolyzer using distilled water with an electrical conductivity of $\sigma < 2 \mu\text{S}/\text{cm}$.

CAUTION

Risk of damage due to electrical overload.

Any operation beyond the electrical specifications will lead to irreparable damage to the electrolyzer. Never operate the electrolyser beyond the electrical specifications stated in the technical data.

NOTE

Water in the fuel cell:

Ensure that no water enters the fuel cell. A film of water on the electrode surface may suppress the reaction of hydrogen and oxygen in the fuel cell. In such cases, the output of the fuel cell will be inadequate.

Technical data

Box:
 H x W x D:.....410 x 300 x 140 mm
 Weight:.....2300 g

Electrolyzer:
 H₂ Production:.....10 mL/min
 O₂ Production:.....5 mL/min
 Permissible Current:.....0 - 1.5 A
 Permissible operating Voltage:.....0 - 2.0 VDC
 Electrode Area:.....3.6 cm²
 Guide value for Distilled Water:.....<2 μS/cm
 Permitted Operating Pressure:.....0 - 20 mbar
 H x W x D:.....51 x 51 x 41 mm
 Weight:.....58 g

Fuel Cell:
 H₂ / O₂ Power Range:.....580 - 640 mW @ 1.5 A
 Electrode Area:.....3.6 cm²
 Permissible Voltage:.....0.45 - 0.96 V DC
 Permitted operating pressure:.....0 - 20 mbar
 H x W x D:.....51 x 51 x 41 mm
 Weight:.....58 g

Solar Module:
 Active solar area:.....approx. 60 cm²
 Open-circuit voltage:.....approx. 2 V DC
 Operating current:.....approx. 350 mA

Gas Storage Tank:
 Water Fill Volume - H₂ Side:.....approx. 150 mL
 Water Fill Volume - O₂ Side:.....approx. 150 mL
 Gas Storage Volume H₂:.....approx. 50 mL
 Gas Storage Volume O₂:.....approx. 50 mL

Fan:
 Permissible operating voltage:.....0.18 - 6 V DC
 Starting current:.....approx. 10 mA
 Rated power consumption:.....approx. 10 mW

Troubleshooting

Despite hydrogen and oxygen being produced, the load connected to the fuel cell is not working.

Possible Cause:

- The load has not been connected correctly or is not receiving any voltage.

Solution:

- Check the connecting cables and the power source.

Possible Cause:

- The JUNIOR Basic needs time to warm up.

Solution:

- Continue running the JUNIOR Basic. In demonstration mode, the product requires a brief warm-up period before the gases produced by the electrolyser reach the fuel cell, where they are converted to water while electrical energy and heat are being generated. Warm-up takes approximately 4 minutes. If lighting conditions are extremely poor, warm-up may take longer.

The fuel cell has a low output.

Possible Cause:

- The fuel cell was stored too dry, or for too long. A fuel cell with a dry polymer electrolyte membrane (PEM) will lose power.

Solution:

- Continue operation. The fuel cell automatically moistens itself during operation, which will slowly let it reach its full capacity again.

Possible Cause:

- Water has entered the fuel cell during operation. This may cause a rapid decline in performance.

Solution:

- Continue operation in demonstration mode. Excess water will be expelled from the fuel cell during operation. Consequently, the fuel cell will slowly return to full capacity.

Troubleshooting

With the solar module connected, no gas is produced in the electrolyzer.

Possible Cause:

- The light intensity is insufficient.

Solution:

- In order to operate solar modules, either adequate direct sunlight or concentrated light from a powerful electrical light source is required. Energy-saving light bulbs, fluorescent tubes etc. are unsuitable for the operation of solar modules.

The load does not work despite a supply voltage being present and the connecting cables being connected correctly.

Possible Cause:

- The load is defective.

Solution:

- Contact H-TEC EDUCATION.

The output of the solar module is insufficient, despite adequate light intensity and the connecting cables being connected correctly.

Possible Cause:

- The solar module is defective.

Solution:

- Contact H-TEC EDUCATION.

Despite correct setup, the electrolyzer or the fuel cell is not working.

Possible Cause:

- No distilled water ($\sigma < 2 \mu\text{S}/\text{cm}$) was used. The electrolyzer and/or the fuel cell has/have sustained irreparable damage.

Should the above-mentioned solutions not remedy the cause of error, please contact H-TEC EDUCATION.

Shutting down

- Continue operating the fuel cells until the load (e.g. the motor) stops independently. This allows some water to remain in the fuel cell, moistening the PEM. This procedure also prevents unnecessary discharge of hydrogen.

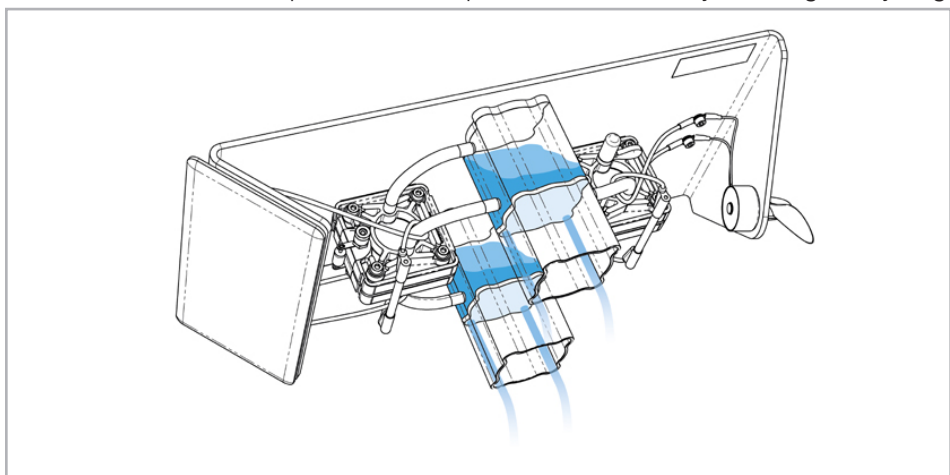

Fig. 7: Draining the gas storage tanks

- Disconnect the power source from the connections on the electrolyzer and replace the transport tube.
- Stored hydrogen needs to be consumed before draining the storage tanks.
- The caps on the fuel cell should be closed before emptying the gas storage tanks.
- Drain the gas storage tanks, as shown in Figure 7.

Before putting the product into storage, observe the following points:

- Close the connections of fuel cells and electrolyzers with caps. This prevents the PEM from drying out. The same applies to stoppers on fuel cells.
- Remove any water droplets from the product with a soft, lint-free cloth. This prevents the formation of water stains. Do not use any cleaning agents.
- Unplug the banana cables from the electrolyzer.

Maintenance

The components of the product do not require maintenance. The following points should be observed, though:

- Use fresh, distilled water ($\sigma < 2 \mu\text{S}/\text{cm}$) for each operation.
- After operation, remove the water from the gas storage tanks.

Transportation and storage

With regard to transportation and storage of the product, the following points should be observed to ensure a long service life. Transport and storage only:

- with the transport tubes on the banana plugs
- in the original packaging
- dry and dust-free
- at temperatures of 4 °C to 50 °C
- protected against vibrations

Disposal

Do not dispose of fuel cells and electrolyzers as general household waste.

WARNING

Fire hazard from catalytic substances
The catalysts for the electrodes of fuel cells and electrolyzers promote burning when they come into contact with flammable substances.
Avoid contact with hydrogen, alcohol fumes or other organic fumes. Ensure correct disposal.

According to European regulations, used electric and electronic devices may no longer be disposed of as unsorted household waste. The symbol of the crossed-out wheellie bin indicates the requirement for separate disposal.

Your local waste management company can provide you with additional information about disposal options.

© H-Tec Education, 2021. No part of this guide may be reproduced in whole or in part in any manner without the express written permission of H-Tec Education. Subject to technical changes.

H-TEC EDUCATION
1902 Pinon Dr. Unit B
College Station, TX 77845
USA
Phone: +1 979-703-1925
Fax: +1 979-314-1122
Email: sales@myhtec.com
Website: www.myhtec.com

